

変更記号	日付	変更内容	備考
△			
△			
△			
△			
△			

上部メッシュ

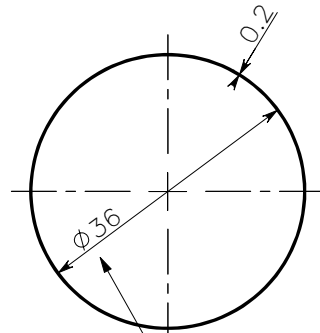

相手側との勘合注意
(圧入)

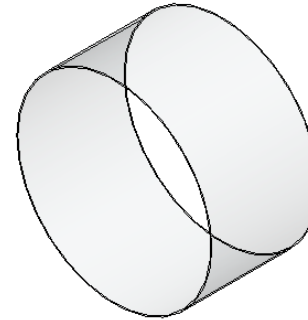
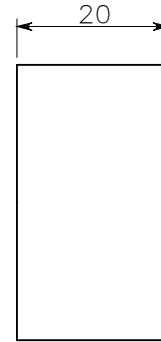

下部メッシュ

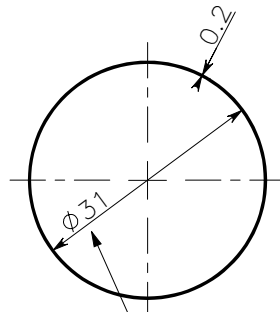

相手側との勘合注意
(圧入)

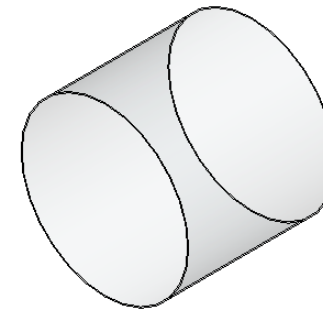
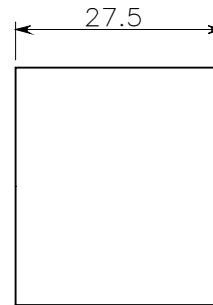

指定外公差	
寸法区分	寸法公差
6mm以下	±0.1
6~18	±0.15
18~30	±0.2
30~50	±0.25
50~120	±0.3
120以上	±0.4
ANGLES	±1°

サンエール株式会社 SUNROX EDM [®]		 尺度材料  図番	1:1	日付	24.3.6	客先
承認	設計 製図					名称
	 奥江  奥江	⑬⑭				